

Simple, versatile and reliable walk behind counterweighted electric forklift truck with tilted forks. Ideal for multiple applications



The 715 FS ac is a walk behind counterweighted electric forklift truck with tilted forks, ideal for situations when you can't use forklift trucks with standard forks (due to special pallets, shelves with safety edge) or trucks that pick the loads frontally (because you might endanger the operators or due to lack of training) Equipped with Fem forks which also allow transversal load picking. The manoeuvrability and versatility of this forklift truck render it a valuable asset that can be used by a variety of different operators for different applications.

Frame

Made of bended sheet metal to minimise any tensions induced by welds, ensuring maximum mechanical resistance over time. The unique configuration with 3 fixed points of support ensures the best lateral stability. The highly visible mast and the central position of the steering handle ensure optimal visibility for load storage, picking and transport. The battery compartment cover is hinged, facilitating battery top-up and daily and periodical maintenance operations. Particular attention was paid to simplify the access to wear parts so as to minimise the routine maintenance costs.

Masts

The OMG masts are made of cold extruded profiles, ensuring high resistance to bending and twisting. The lift cylinders are installed outside of the mast profiles and the chains are protected to ensure perfect visibility and maximum safety. Available in simplex, duplex and triplex version with wide free lift. The tilting function comes as standard and facilitates goods picking and storage.

Hydraulic functions

The 3kW powerful and silent lift motor with high torque ration offers high performance with low power consumption. The pumps are highly efficient and very quiet. The mini joystick installed on the tiller (finger touch) allows the operator to lift and lower the forks without releasing the tiller. The truck comes with standard tilting function and can also be fitted with built-in shifter on request.

Drive

Powerful and reliable AC traction motor, capable of meeting even the most demanding requests in terms of performance, under any conditions. Travel speed controlled directly by the throttle installed on the tiller.

Electronic system

The OMG machines are fitted with AC control with energy recovery, that can be enabled by:

- releasing the drive control on the tiller;
 - reversing the running direction also using the drive control on the tiller;
- From this control, the operator can manage all truck's functions and carry out unlimited adjustments for performance optimisation, adapting the

machine to any application, while ensuring silent operation and low power consumption at the same time.

The 715 FS ac is equipped with a 24V 375Ah battery. The lateral battery extraction system is a standard feature on all versions, very useful for multiple work shifts. With the wo-wa battery charger installed on-board (optional) you can recharge your truck from any socket.



The rear opening on the chassis facilitates maintenance, allowing the operator to check or replace the drive wheel without lifting the truck.



The mini joystick (finger touch) allows the operator to control the truck by simply moving his finger along the tiller, ensuring precise and smooth load lifting and lowering, without taking his hands off the tiller. The electronic control comes with IP 65 protection rating and is waterproof and dustproof. The tiller head can also be manufactured with IP55 protection rating for protection against dust and water (standard feature for cold store versions).



The new polyethylene casings have an innovative simple to use opening system that can be used to gain access to the main components during maintenance operations.



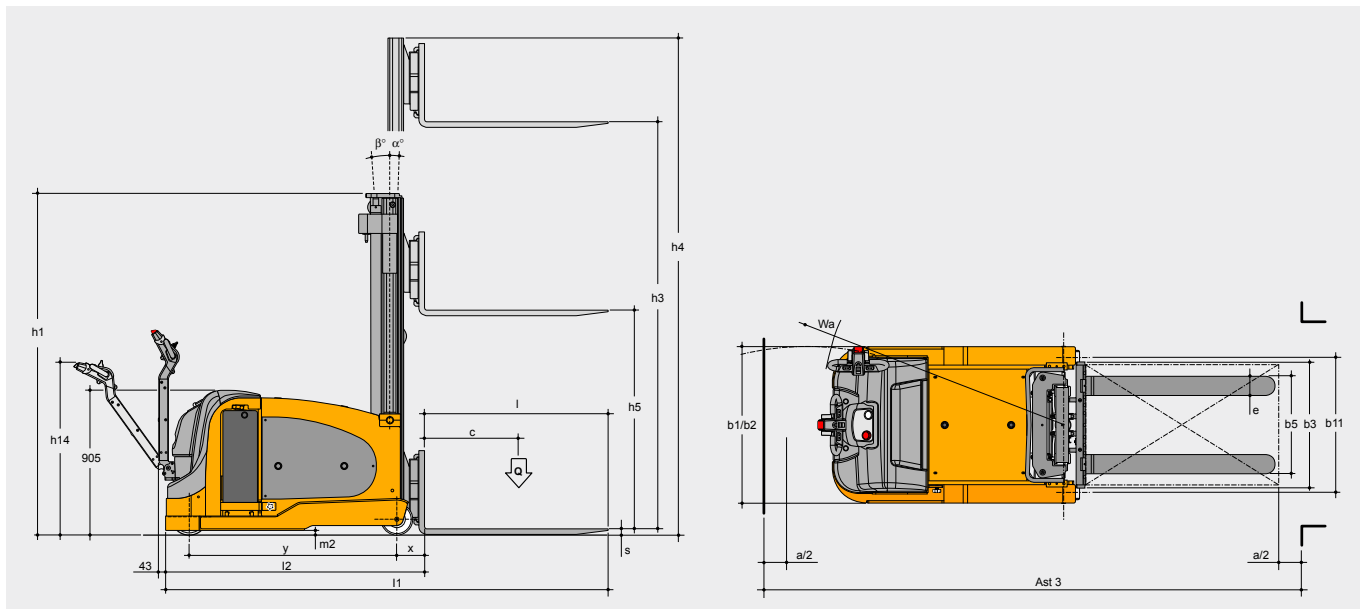

Accessories and special features

total free lift for duplex column	■	access keypad with pin code	■
total free lift for triplex column	■	anti roll-back device	■
protection for cold storage	■	electronic speed control	■
supertrack drive wheel	■	electronic braking system	■
polyurethane drive wheel	■	electromagnetic parking brake	■
low speed push-button with tiller in vertical position	■	voltmeter-timer, auto-lock function when 80% of the battery capacity is discharged	■
servo-assisted tiller	■	24V 45A current rectifier on-board	■
lateral battery extraction system	■	3 rd hydraulic way with built-in side shift	■
roller for lateral battery extraction	■	24V 375Ah traction battery 24V 60A rectifier	■
double lateral battery extraction roller with wheels	■	tilting mast	■

standard ■ optional ■

Standard masts							Capacity
Description	Lowered mast height	Forks lifting stroke	Total lifting	Extended mast height	Free lift	Mast tilting system	(t) c=600 mm
	h1	h3	h3+h13	h4	h2	/	
Simplex	mm 2,110	1,590	1,650	2,110	1,565	4 / 1	1.5
Duplex	mm 1,885	2,540	2,600	3,160	1,275 *	4 / 1	1.5
	mm 2,135	3,040	3,100	3,660	1,525 *	4 / 1	1.2
Triplex GAL	mm 2,385	3,540	3,600	4,160	1,775 *	4 / 1	1.0
	mm 1,895	3,840	3,900	4,430	1,275	4 / 1	0.8
	mm 1,895	4,140	4,200	4,730	1,375	4 / 1	0.7

* optional

Characteristics	1.1	Manufacturer			OMG S.r.l. Single member company	
	1.2	Model			715 FS ac	
		Execution				
	1.3	Operation			Electric	
	1.4	Operator position			at ground level	
	1.5	Capacity	Q	t	1.5	
		Mast lift capacity	Q	t		
		Forks lift capacity	Q	t		
		Forks + mast lift capacity	Q	t		
	1.6	Load centre of gravity	c	mm	600	
1.8	Load distance	x	mm	174		
1.9	Wheel centre distance	y	mm	1,300		
Weights	2.1	Truck weight incl. battery (see line 6.5)			kg	2,190
	2.2	Weight on axis with front / rear load			kg	900 / 1,290
	2.3	Weight on axis without front / rear load			kg	3,346/404
Wheels Frame	3.1	Wheels and tyres			polyurethane	
	3.2	Front wheel size			mm	150
	3.3	Rear wheels size			mm	230
	3.4	Stabiliser wheels size			mm	
	3.5	Number of front / rear wheels (x = drive)			no.	1x / 2
	3.6	Front track	b ₁₀	mm	/	
	3.7	Rear track	b ₁₁	mm	850	
Base dimensions	4.2	Lowered mast height	h ₁	mm	1,885	
	4.3	Free lift	h ₂	mm	1,275	
	4.4	Forks lifting stroke	h ₃	mm	2,540	
	4.5	Extended mast height	h ₄	mm	3,160	
	4.6	Initial lift	h ₅	mm	/	
	4.9	Tiller height in min. /max. driving position	h ₁₄	mm	740 / 1,300	
	4.15	Forks lowered height	h ₁₃	mm	60	
	4.19	Overall length	l ₁	mm	2,772	
	4.20	Length including forks heel	l ₂	m	1,622	
	4.21	Overall width	b ₁ / b ₂	mm	980	
	4.22	Forks size	s/e/l	mm	35 / 120 / 1,150	
	4.23	Forks support plate ISO 2328, class /type A, B			Fem 2A	
	4.24	Forks support plate width	b ₃	mm	800	
	4.25	Width over forks	b ₅	mm	750	
	4.32	Clearance at mid stroke	m ₂	mm	30	
	4.33	Working aisle width with 1000 x 1200 transversal pallet	Ast	mm	3,173	
4.34	Working aisle width with 800 x 1200 longitudinal pallet	Ast	mm	3,208		
4.35	Turning radius	W _a	mm	1,745		
Performance	5.1	Speed with / without load			km/h	5 / 5.5
	5.2	Lifting speed with / without load			m/s	0.14 / 0.18
	5.3	Lowering speed with/without load			m/s	0.38 / 0.30
	5.8	Max. feasible gradient with / without load			%	6 / 10
	5.10	Service brake			Electromagnetic	
Electric motors	6.1	Traction motor, 60 min performance with S2			kW	1.2
	6.2	Lift motor, 15% performance with S3			kW	3
	6.3	Battery as per DIN 43531 / 35 / 36 A, B, C, no			43531 A	
	6.4	K5 battery voltage, nominal capacity			V/Ah	24 / 375
	6.5	Battery weight			kg	302
	6.6	Power consumption as per VDI cycle			kW/h	
Miscellaneous	8.1	Type of electronic system			ac	
	8.4	Noise threshold as per EN 12 053			dB(A)	< 70
					*optional	

Technical data sheet referring to pallet truck in standard version; data determined in compliance with VDI 2198. These values may differ if your product is fitted with other types of wheels and tires, supports and accessories. All data and images herein are indicative, OMG S.r.l. Single member company reserves the right to modify the documentation without prior notice.