



## T35100SL | Telescopic Handlers



## Performance

|   |            |
|---|------------|
| Lifting height — on stabilisers         | 11080.0 mm |
| Lifting height — on tyres               | 10770.0 mm |
| Rated capacity                          | 3500 kg    |
| Capacity (at max. height)               | 3200 kg    |
| Capacity (at max. height on tyres)      | 2500 kg    |
| Capacity (at max. reach on stabilisers) | 1200 kg    |
| Capacity (at max. reach on tyres)       | 500 kg     |
| Max. reach on stabilisers               | 7360.0 mm  |
| Max. reach on tyres                     | 7450.0 mm  |
| Crowding force                          | 4600 daN   |

## Weights

|                  |         |
|------------------|---------|
| Weight (unladen) | 8124 kg |
|------------------|---------|

## Traction

|                              |  |
|------------------------------|--|
| Standard tyres               | TITAN 400/70x20 150B 166A2 LIFT RIGGER II (4 bar front/rear) |
| Low speed (forward/reverse)  | 7.0 km/h   |
| High speed (forward/reverse) | 30.0 km/h  |
| Driving modes                | Direct drive / soft drive                                    |

## Drive System

|              |  |
|--------------|--|
| Main drive   | 2-speed hydrostatic motor              |
| Transmission | Hydrostatic with electronic regulation |

## Engine

|                                    |                            |
|------------------------------------|----------------------------|
| Make / Model                       | PERKINS / 1104D-44TA turbo |
| Fuel                               | Diesel                     |
| Cooling                            | Liquid                     |
| Rated power (DIN 6271) at 2200 RPM | 74.5 kW                    |
| Maximum torque at 1400 RPM         | 410.0 Nm                   |
| Number of cylinders                | 4                          |
| Displacement                       | 4.40 L                     |

## Hydraulic System

|                        |                         |
|------------------------|-------------------------|
| Pump type              | Gear pump with LS valve |
| Combined pump capacity | 135.00 L/min            |
| Working pressure       | 265.00 bar              |

## Cycle Times

|   |        |
|---|--------|
| Lift time - no load                         | 10.0 s |
| Lower time - no load                        | 5.0 s  |
| Telescope in time at max. reach - no load   | 9.3 s  |
| Telescope in time at max. height - no load  | 9.3 s  |
| Telescope out time at max. reach - no load  | 11.0 s |
| Telescope out time at max. height - no load | 11.2 s |

## Brakes

|                             |                                       |
|-----------------------------|---------------------------------------|
| Engine braking              | Hydrostatic                           |
| Parking and emergency brake | Negative brake with hydraulic command |

## Fluid Capacities

|  |           |
|--|-----------|
| Axles and reduction gears front / rear | 9.0/8.1 L |
| Engine oil                             | 8.50 L    |
| Fuel tank                              | 140.00 L  |
| Hydraulic reservoir                    | 77.00 L   |

## Standard Features

|                                      |  |
|--------------------------------------|--|
| Aggravating Movements Arrester (AMA) | Right and left side mirrors                          |
| Hydrostatic transmission             | Two way hydraulic supply at the end of the boom      |
| ROPS/FOPS operator cab               | Mudguards  |
| Heating, demisting and ventilation   | Turbo-charged engine                                 |
| Front and rear washer/wipers         | Narrow hook-up for mounting of the equipment         |
| Suspension seat                      | Mechanical lock of the equipment                     |
| Road lights                          | Four TITAN 400/70x20 150B 166A2 Lift Rigger II tyres |
| Turn signals                         |  |

## Options

|                                   |   |
|-----------------------------------|---|
| Back up alarm                     | Work light on boom                      |
| Second hydraulic function on boom | Set of blue lights for hen houses       |
| Air conditioning                  | Carriage with hydraulic attachment lock |
| Rear hydraulic hook and mirror    | Yoke and electrical plug                |

## Load Charts

With forks and TITAN 400/70 x 20 150B 166A2 LIFT RIGGER II (standard) or DUNLOP 400/70 x 20 150B 168A2 (option) tyres — on tyres

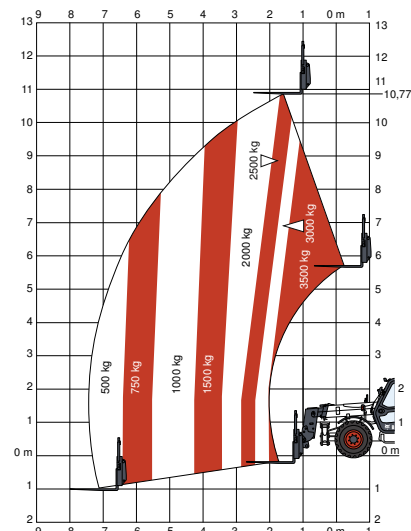

Complies with stability test EN1459 Annex B

## Dimensions

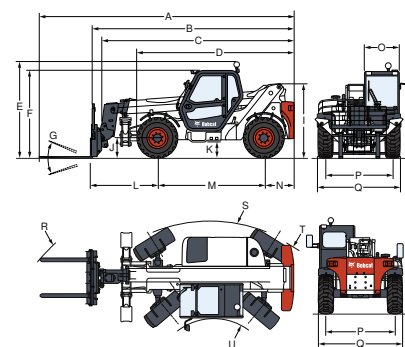

|               |               |
|---------------|---------------|
| (-) 1600.0 mm | (I) 2079.0 mm |
| (-) 920.0 mm  | (J) 419.0 mm  |
| (-) 1165.0 mm | (M) 2850.0 mm |
| (-) 4340.0 mm | (N) 800.0 mm  |
| (-) 120.0 mm  | (O) 930.0 mm  |
| (-) 2475.0 mm | (P) 1812.0 mm |
| (A) 6864.0 mm | (Q) 2216.0 mm |
| (B) 5660.0 mm | (R) 5375.0 mm |
| (C) 5584.0 mm | (R) 5300.0 mm |
| (D) 4406.0 mm | (R) 5440.0 mm |
| (E) 2610.0 mm | (S) 3900.0 mm |
| (F) 2295.0 mm | (T) 3965.0 mm |
| (G) 145°      | (U) 1370.0 mm |



www.bobcat.eu