

SBP10N2
 SBP12N2(I)
 SBP12N2(I)R
 SBP14N2(I)
 SBP14N2(I)R
 SBP16N2(I)
 SBP16N2(I)R
 SBP16N2S
 SBP16N2SR

AXIA ES

Pedestrian Stacker • AC Power
 1.0 – 1.6 tonnes

Big performance... even in the smallest spaces

Compact, easy to use and highly versatile, AXIA ES stackers have been developed to deliver exceptional productivity in every setting.

An ergonomic tiller arm and extremely compact powerhead, coupled with a very narrow chassis and outstanding visibility, ensure excellent manoeuvrability in tight spaces, such as on board road vehicles or in block stacking.

Frame and body

- **Sealed chassis** offers protection against dirt, dust and other particles to reduce wear.
 - **Water-resistant design** diverts splashed moisture away from key electrical components, for long truck life.
 - **Low centre of gravity** aids stability, for safe operation.
 - **High-visibility design** maximises view of fork tips and working area.
- ### Mast and fork assembly
- **Robust forks** with welded construction, and rounded tips for effortless pallet entry, give extra strength and durability.
 - **Straddle leg version** allows adjustment of distance between support legs to suit pallet width (SBP16N2S only).
 - **Wide range of lift heights and mast types** includes triplex masts on 1.2 to 1.6 tonne models and a choice between standard or free lift masts.

Drive

- **Powerful AC drive motor** gives excellent traction and ramp performance, as well as smooth, quiet, controlled operation, extended shift length and lower maintenance requirements.
- **Oil-filled, sealed transmission** is shock-resistant, quiet and requires little maintenance.



when **reliability** is everything

Like any product bearing the Mitsubishi name, our materials handling equipment benefits from the huge resources and cutting-edge technology of one of the world's largest corporations. So when we promise you **quality, reliability** and **value for money**, you know it's a guarantee we have the power to deliver.

Every model in our comprehensive, award-winning range of forklift trucks and warehouse equipment is built to a high specification and is designed to keep on working for you... day after day... year after year... whatever the job... whatever the conditions.

To ensure your truck stays in constant productive action, we have a network of local dealers – hand-picked for their commitment to customer care... and backed up by the Mitsubishi Forklift Trucks organisation. No matter where you are, we have a dealer close by – ready and willing to meet your needs.

That friendly local service covers everything from identifying the perfect model and configuration for your application to providing competitive, flexible finance and maintenance packages, unbeatable warranties, long and short term hire, and highly responsive field service and repairs... as well as the industry's quickest and most reliable parts supply.

Only Mitsubishi can give you this combination of global engineering excellence and outstanding local support... only Mitsubishi offers you such a quality product at such an affordable price... and only Mitsubishi places reliability as high as you do in its priorities. Contact us now and see what we can do for you.

www.mitforklift.com



WESM1823 (11/16)
 © 2016 MCFE
 Printed in The Netherlands

mitforklift@mcf.nl www.mitforklift.com

NOTE: Performance specifications may vary depending on standard manufacturing tolerances, vehicle condition, types of tyres, floor or surface conditions, applications or operating environment. Trucks may be shown with non-standard options. Specific performance requirements and locally available configurations should be discussed with your distributor of Mitsubishi forklift trucks. Mitsubishi follows a policy of continual product improvement. For this reason, some materials, options and specifications could change without notice.

Steering system

- **State-of-the-art tiller arm** offers the ultimate in ergonomic design, comfort and safety.
- **Small turning circle** together with compact chassis and excellent visibility means exceptional manoeuvrability.

Brakes

- **Regenerative braking** gives effective control, without brake wear, and extends shift life.
- **Parking brake** is automatically activated, when necessary, for extra safety on ramps.

Electrical and control systems

- **High-efficiency electronic system** features waterproof components for maximum reliability – even in moist conditions.
- **Programmable controller** adjusts acceleration, travel speed and braking to suit the application and operator – for greater versatility.
- **On-board diagnostics** and fault memory folder speed up servicing and help prevent damage.
- **Versatile battery compartment** accommodates DIN and BS size batteries with a variety of capacities for maximum compatibility with user's equipment and needs.

Operator environment and controls

- **Spacious, suspended foldable platform** allows operator to ride in comfort – maximum speed 6 km/h – during occasional longer travel (R models only).
- **Choice of two performance modes** via key switch enhances safety, energy efficiency and productivity.
- **Creep speed function and tiller arm lock bypass** maximise safety and control in confined spaces.
- **Unique crossbar design** deflects obstacles away from tiller arm and operator's hand, protecting both truck and operator.
- **Easy-to-operate controls** reduce operator fatigue and minimise mistakes to enhance safety.
- **Ergonomic levers** allow operators to raise and lower loads with ease – even when wearing gloves.
- **Battery discharge indicator** is fitted as standard for battery protection and monitoring of truck use.
- **Ground clearance** is only 20 mm – which makes foot trapping very unlikely.

Options include:

- Choice of drive and load wheels for different applications
- Load backrest
- Wide variety of fork dimensions
- Battery changing device
- Sealed inbuilt charger
- PIN code pad
- Cold store modification (class III, -35°C)
- Multifunctional display with hour meter
- Equipment bar for mounting accessories (on most models)
- Space for 375 Ah battery

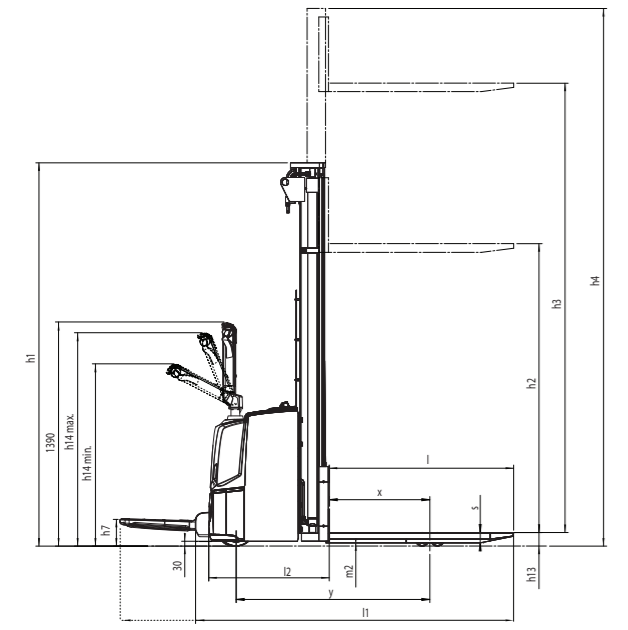

SBP12/14/16N2R: with folding platform

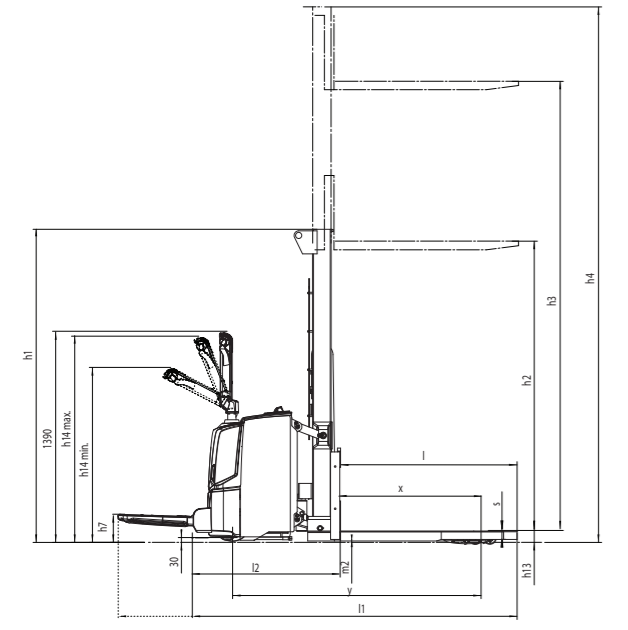
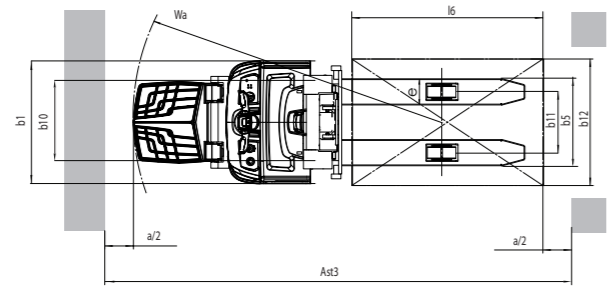

SBP12i/14i/16iN2R: with folding platform

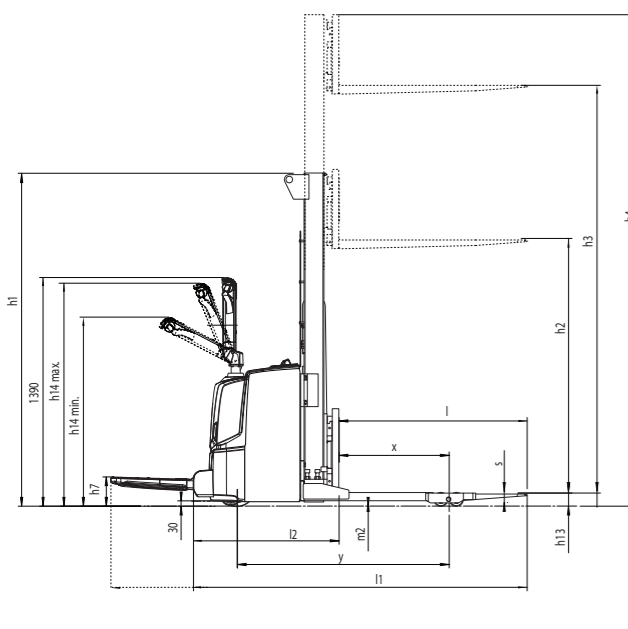
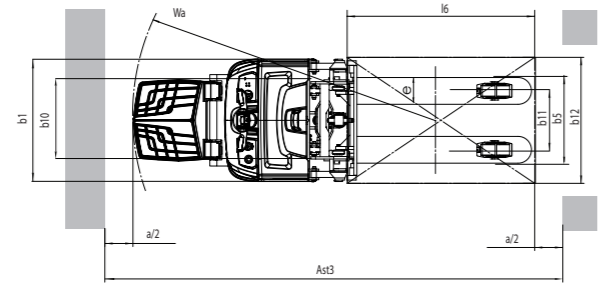

SBP16N2SR: with folding platform

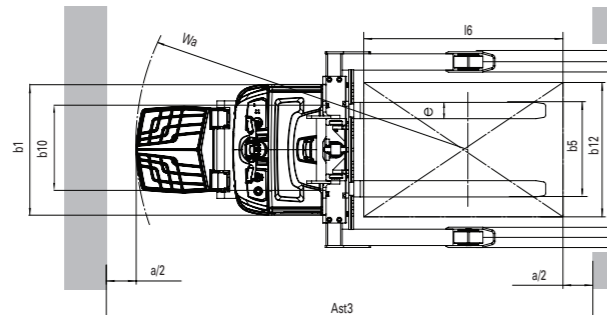

Mast Performance and Capacity

SBP10N2				
Mast Type	h3+h13 mm	h1 mm	h4 mm	h2+h13 mm
Simplex	1500	1980	1980	1500
	2500	1775	3000	195
Duplex	2900	1975	3400	195
	3300	2175	3800	195

SBP12/14/16N2 / SBP12/14/16N2R				
Mast Type	h3+h13 mm	h1 mm	h4 mm	h2+h13 mm
Simplex	1500	1950	1950	1500
	2500	1835	3000	200
Duplex	2900	2035	3400	200
	3300	2235	3800	200
	3600	2385	4100	200
	4300	2735	4800	200
Duplex Free-lift	2500	1775	2940	1355
	2900	1975	3340	1555
Triplex	4300	2020	4840	1540
	4700	2153	5240	1673
Triplex Free-lift	4300	2020	4840	1540
	4700	2153	5240	1673

SBP16N2S / SBP16N2SR				
Mast Type	h3+h13 mm	h1 mm	h4 mm	h2+h13 mm
Simplex	1500	2030	2030	1500
	2500	1915	3080	195
Duplex	2900	2115	3480	195
	3300	2315	3880	195
	3600	2465	4180	195
	4300	2815	4880	195
Duplex Free-lift	2500	1915	3080	1355
	2900	2115	3480	1555
Triplex	4300	2100	4920	1540
	4700	2233	5320	1753
Triplex Free-lift	4300	2100	4920	1540
	4700	2233	5320	1753

- * = Only SBP14N2-16N2 & SBP14N2i-16N2i
- S = Simplex
- DS = Duplex with clear-view mast
- DEV = Duplex with full free lift
- TR = Triplex with clear-view mast
- TREV = Triplex with full free lift
- h3+h13 = Lifting height
- h1 = Lowered mast height
- h4 = Raised mast height
- h2+h13 = Free lift

AXIA ES
Pedestrian Stacker
AC Power • 1.6 – 2.0 tonnes

Characteristics											
1.01	Manufacturer		Mitsubishi	Mitsubishi	Mitsubishi	Mitsubishi	Mitsubishi	Mitsubishi	Mitsubishi	Mitsubishi	Mitsubishi
1.02	Manufacturer's model designation		SBP10N2	SBP12N2(i)	SBP14N2(i)	SBP16N2(i)	SBP12N2(i)R	SBP14N2(i)R	SBP16N2(i)R	SBP16N2S	SBP16N2SR
1.03	Power source: (battery, diesel, LP gas, petrol)		Battery	Battery	Battery	Battery	Battery	Battery	Battery	Battery	Battery
1.04	Operator type: pedestrian, (operator)-standing, -seated		Pedestrian	Pedestrian	Pedestrian	Pedestrian	Pedestrian/Stand-on	Pedestrian/Stand-on	Pedestrian/Stand-on	Pedestrian	Pedestrian/Stand-on
1.05	Load capacity	Q (kg)	1000	1200	1400	1600	1200	1400	1600	1600	1600
1.06	Load center distance	c (mm)	600	600	600	600	600	600	600	600	600
1.08	Load wheel axle to fork face (forks lowered)	x (mm)	625	625 (925)	625 (925)	625 (925)	625 (925)	625 (925)	625 (925)	650	650
1.09	Wheelbase	y (mm)	1141	1205 (1615)	1205 (1615)	1205 (1615)	1205 (1615)	1205 (1615)	1205 (1615)	1295	1295
Weight											
2.01	Truck weight with load, with maximum battery weight	(kg)	820	1205 (1350)		1220 (1395)	1225 (1400)	1245 (1390)	1260 (1435)	1265 (1440)	1397
2.02	Axle loadings with nominal load & maximum battery weight, drive/load side	(kg)	740 / 1080	830 (1180) / 1575 (1370)		835 (1275) / 1785 (1555)	835 (1275) / 1990 (1725)	870 (1220) / 1575 (1370)	875 (1280) / 1785 (1555)	875 (1315) / 1990 (1725)	1941 / 1056
2.03	Axle loadings without load & with maximum battery weight, drive/load side	(kg)	605 / 215	820 (955) / 385 (395)		825 (970) / 395 (425)	825 (970) / 400 (430)	860 (995) / 385 (395)	865 (1010) / 395 (425)	865 (1010) / 400 (430)	945 / 452
Wheels, Drive Train											
3.01	Tyres: PT=Power Thane, Vul=Vulkollan, drive/load side		Vul / Vul	Vul / Vul		Vul / Vul	Vul / Vul	Vul / Vul	Vul / Vul	Vul / Vul	Vul / Vul
3.02	Tyre dimensions, drive side	(mm)	230 x 70	230 x 70		230 x 70	230 x 70	230 x 70	230 x 70	230 x 70	230 x 70
3.03	Tyre dimensions, load side	(mm)	85 x 90	85 x 90		85 x 75	85 x 75	85 x 90	85 x 75	85 x 75	85 x 75
3.04	Castor wheel dimensions (diameter x width)	(mm)	125 x 60	125 x 60		125 x 60	125 x 60	125 x 60	125 x 60	125 x 60	125 x 60
3.05	Number of wheels, load/drive side (x=driven)	(mm)	1 + 1x/2	1 + 1x/2		1 + 1x/4	1 + 1x/4	1 + 1x/2	1 + 1x/4	1 + 1x/4	1 + 1x/4
3.06	Track width (center of tyres), drive side	b10 (mm)	517	517		517	517	517	517	517	517
3.07	Track width (center of tyres), load side	b11 (mm)	385	385		385	385	385	385	385	385
Dimensions											
4.02	Height with mast lowered	h1 (mm)	see tables	see tables		see tables	see tables	see tables	see tables	see tables	see tables
4.03	Free lift	h2 (mm)	see tables	see tables		see tables	see tables	see tables	see tables	see tables	see tables
4.04	Lift height	h3+h13 (mm)	see tables	see tables		see tables	see tables	see tables	see tables	see tables	see tables
4.05	Height with mast extended	h4 (mm)	see tables	see tables		see tables	see tables	see tables	see tables	see tables	see tables
4.06	Initial lift	h5 (mm)	see tables	see tables		see tables	see tables	see tables	see tables	see tables	see tables
4.09	Height of tiller arm / steering console (min./max.)	h14 (mm)	1050 / 1372	1050 / 1372		1050 / 1372	1050 / 1372	1150 / 1350	1150 / 1350	1150 / 1350	1150 / 1350
4.15	Fork height, fully lowered	h13 (mm)	90	90		90	90	90	90	85	85
4.19	Overall length	l1 (mm)	1836	1900 (2007)		1900 (2007)	1900 (2007)	2020 (2127) / 2500 (2607)	2020 (2127) / 2500 (2607)	1967	2087 / 2567
4.20	Length to fork face	l2 (mm)	686	750 (857)		750 (857)	750 (857)	870(977)/1350(1457)	870(977)/1350(1457)	817	937 / 1417
4.21	Overall width	b1/b2 (mm)	800	800		800	800	800	800	800 / 1140-1575	800 / 1140-1575
4.22	Fork dimensions (thickness, width, length)	s/e/l (mm)	56 / 186 / 1150	56 / 186 / 1150		56 / 186 / 1150	56 / 186 / 1150	56 / 186 / 1150	56 / 186 / 1150	40 / 100 / 1150	40 / 100 / 1150
4.24	Fork carriage width	b3 (mm)	752	752		752	752	752	752	980	980
4.25	Outside width over forks (minimum/maximum)	b5 (mm)	570	570		570	570	570	570	260-900	260-900
4.26	Innerwidth of support legs	b4 (mm)	-	-		-	-	-	-	1015-1450	1015-1450
4.32	Ground clearance at center of wheelbase, (forks lowered)	m2 (mm)	20	20		20	20	20	20	20	20
4.33a	Working aisle width (Ast) with 1000 x 1200 mm pallets, load crosswise, platform up/down	Ast (mm)	2291	2355 (2653)		2355 (2653)	2355 (2653)	2475 (2773) / 2955 (3253)	2475 (2773) / 2955 (3253)	2430	2550 / 3030
4.33b	Working aisle width (Ast3) with 1000 x 1200 mm pallets, load crosswise, platform up/down	Ast3 (mm)	1958	2022 (2123)		2022 (2123)	2022 (2123)	2142 (2243) / 2622 (2723)	2142 (2243) / 2622 (2723)	2085	2205 / 2685
4.34a	Working aisle width (Ast) with 800 x 1200 mm pallets, load lengthwise, platform up/down	Ast (mm)	2283	2347 (2533)		2347 (2533)	2347 (2533)	2467 (2653) / 2947 (3133)	2467 (2653) / 2947 (3133)	2415	2535 / 3015
4.34b	Working aisle width (Ast3) with 800 x 1200 mm pallets, load lengthwise, platform up/down	Ast3 (mm)	2158	2222 (2323)		2222 (2323)	2222 (2323)	2342 (2443) / 2822 (2923)	2342 (2443) / 2822 (2923)	2285	2405 / 2885
4.35	Turning radius	Wa (mm)	1383	1447 (1848)		1447 (1848)	1447 (1848)	1567 (1968) / 2047 (2448)	1567 (1968) / 2047 (2448)	1535	1655 / 2135
Performance											
5.01	Travel speed, with/without load	(km/h)	6.0 / 6.0	6.0 / 6.0		6.0 / 6.0	6.0 / 6.0	6.0 / 6.0	6.0 / 6.0	6.0 / 6.0	6.0 / 6.0
5.02	Lifting speed, with/without load	(m/s)	0.12 / 0.26	0.12 / 0.26		0.12 / 0.26	0.14 / 0.27	0.12 / 0.26	0.12 / 0.26	0.14 / 0.27	0.14 / 0.27
5.03	Lowering speed, with/without load	(m/s)	0.35 / 0.40	0.35 / 0.40		0.35 / 0.40	0.35 / 0.40	0.35 / 0.40	0.35 / 0.40	0.35 / 0.40	0.35 / 0.40
5.08	Maximum gradeability, with/without load	(%)	8 / 15	8 / 15		8 / 15	8 / 15	8 / 15	8 / 15	8 / 15	8 / 15
5.10	Service brake	(s)	Electric	Electric		Electric	Electric	Electric	Electric	Electric	Electric
Electric motors											
6.01	Drive motor capacity (60 min. short duty)	(kW)	1.0	1.0		1.0	1.0	1.0	1.0	1.0	1.0
6.02	Lift motor output at 15% duty factor	(kW/%)	2.2	2.2		2.2	3.2	2.2	2.2	3.2	3.2
6.04	Battery voltage/capacity at 5-hour discharge	(V/Ah)	24 / 150	24 / 150-250		24 / 250	24 / 250-375	24 / 250-250	24 / 250	24 / 250-375	24 / 250-375
6.05	Battery weight	(kg)	151	151-212		212	212-294	151-212	212	212-294	212-294
Miscellaneous											
8.01	Type of drive control		Stepless	Stepless		Stepless	Stepless	Stepless	Stepless	Stepless	Stepless
8.04	Level of noise at the ear level of the driver according to EN 12 053:2001 and EN ISO 4871 in work LpAZ	(dB(A))	60 / 60 / 41	60 / 60 / 41		60 / 60 / 41	70 / 72 / 41	60 / 60 / 41	60 / 60 / 41	70 / 72 / 41	70 / 72 / 41
	Body vibration (EN 13 059)	m/s ²	-	-		-	-	0.8	0.8	-	0.8
	Hand-arm vibration (EN 13 059)	m/s ²	< 2.5	< 2.5		< 2.5	< 2.5	< 2.5	< 2.5	< 2.5	< 2.5

Values in brackets () are for initial lift versions. All values are measured with standard configuration. Values can vary with different masts.

Continuing improvement may lead to changes in these specifications.



Outstanding visibility



Excellent manoeuvrability



Foldable platform models



Protective tiller arm design



Initial lift for ramps



Straddle leg version

AXIA ES
THE ALL ROUNDER

With a name that reflects its manoeuvrability, AXIA combines award-winning ergonomics with high performance and low maintenance features to deliver a complete warehouse support package.

Efficient, versatile and durable, AXIA is the perfect choice for every workplace.

SBP10/12/14/16N2

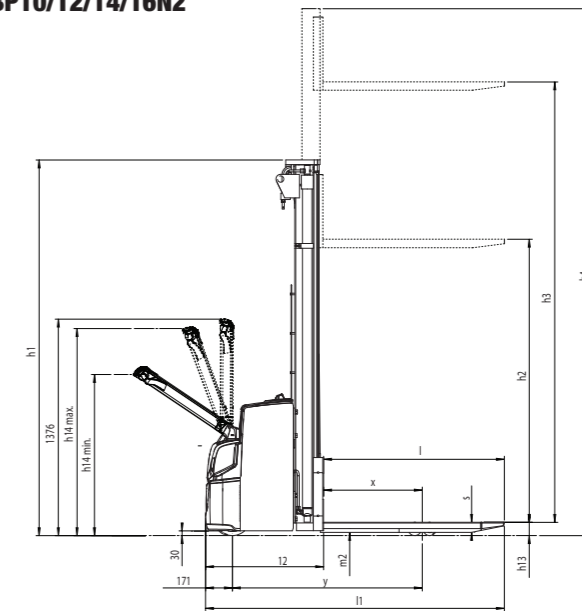

Ast = Working aisle width
Ast3 = Working aisle width (b12 < 1000 mm)
Ast = Wa + √(Wa - x)² + (b12 / 2)² + a
Ast3 = Wa + √(Wa - x)² + a
Wa = Turning radius
∅ = Pallet length
x = Load wheel axle to fork face
b12 = Pallet width
a = Safety clearance = 2 x 100 mm

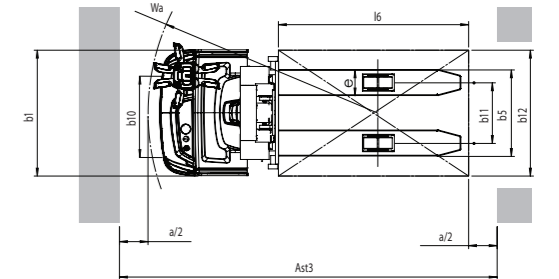

SBP12/14/16IN2

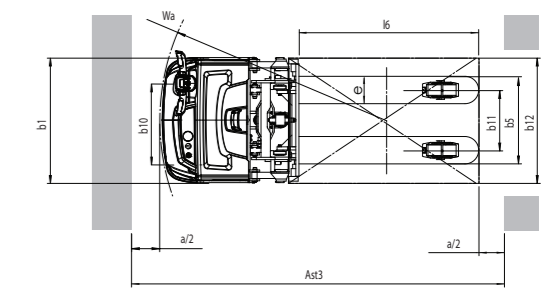
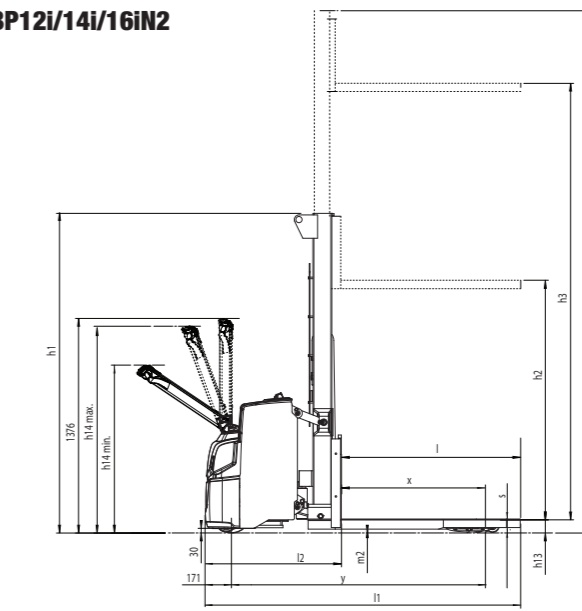

SBP16N2S

