

EDIA EM

Electric Counterbalance • 3 & 4 Wheel Pneumatic Tyres
48 Volt • **1.3 – 2.0 tonnes**

Effortless ease... total control

Over 20 years of independent tests don't lie. The single most important factor in increasing the productivity of a forklift truck is 'driveability'. It results from a combination of characteristics that allow the operator to be at one with the machine. Almost without thinking. Entirely without surprises. Totally in control. This is what drives our designers... and now brings you EDIA EM – our latest series of 1.3 to 2.0 tonne, 48V, 3 and 4 wheel electric counterbalance forklift trucks.

Smooth, quiet and highly responsive electric steering, matched with user-friendly hydraulics, gives a sense of effortless control and makes operation a pleasure. Space, comfort, intuitively placed controls, easy access and clear views in all directions are built into the design. A host of safety features boost confidence still further – allowing your operator to focus entirely on delivering the goods.

Operator compartment and controls

- **Market-leading ErgoCentric design** results in large, flat, uncluttered floor space, exceptionally large 'entry window' with deep, wide step and convenient grab bar, user-friendly controls, practical layout and great all-round visibility.
- **FeatherTouch steering wheel** maximises control, confidence and comfort, thanks to small size, low-effort operation and force feedback.
- **Multi-function colour display** provides highly visible readouts, even in bright sunlight, keeping operator fully informed of programmed settings, performance, condition and faults.
- **Ergonomic hydraulic levers** give a strong sense of touch, as well as control of speed, even if operator wears gloves.
- **Optional fingertip hydraulic control unit** with fully adjustable armrest (an award-winning concept) allows effortless precision.
- **Low-noise technology** reduces average sound level at operator's ear to a market-leading 66 dB(A) for 3 wheel and 67 dB(A) for 4 wheel models.
- **High-quality VersaCab factory-fitted panel cabin options** include unique, award-winning, hi-vis overhead guard roof, glass windows with wash/wipe, PVC or steel doors and heating.



Electric Counterbalance

3 Wheel Pneumatic Tyres • 48 Volt AC Power • 1.3 – 2.0 tonnes

Characteristics					
1.1	Manufacturer (abbreviation)			Mitsubishi	Mitsubishi
1.2	Manufacturer's model designation			FB13PNT	FB15PNT
1.3	Power source: (battery, diesel, LP gas, petrol)			Electric	Electric
1.4	Operator type: pedestrian, (operator)-standing, -seated			Seated	Seated
1.5	Load capacity	Q	kg	1,300	1,500
1.6	Load center distance	c	(mm)	500	500
1.8	Load distance, axle to fork face	x	(mm)	373	373
1.9	Wheelbase	y	(mm)	1285	1285
Weight					
2.1	Truck weight, without load / including battery (simplex mast, lowest lift height)		kg	2779	2972
2.2	Axle loading with maximum load, front/rear (simplex mast, lowest lift height)		kg	3564/515	3897/575
2.3	Axle loading without load, front/rear (simplex mast, lowest lift height)		kg	1381/1398	1378/1594
Wheels, Drive Train					
3.1	Tyres: V=solid, L=pneumatic, SE=solid pneumatic - front/rear			SE / SE	SE / SE
3.2	Tyre dimensions, front			18x7-8	18x7-8
3.3	Tyre dimensions, rear			140/55-9	140/55-9
3.5	Number of wheels, front/rear (x=driven)			2x/2	2x/2
3.6	Track width (center of tyres), front	b10	(mm)	920	920
3.7	Track width (center of tyres), rear	b11	(mm)	174	174
Dimensions					
4.1	Mast tilt, forwards/backwards	α/β	°	5/7.5	5/7.5
4.2	Height with mast lowered (see tables)	h1	(mm)	2125	2125
4.3	Free lift (see tables)	h2	(mm)	80	80
4.4	Lift height (see tables)	h3	(mm)	3290	3290
4.5	Overall height with mast raised	h4	(mm)	4342	4342
4.7	Height to top of overhead guard	h6	(mm)	2050	2050
4.8	Seat height	h7	(mm)	974	974
4.12	Tow coupling height	h10	(mm)	575	575
4.19	Overall length	l1	(mm)	2998	2998
4.20	Length to fork face (includes fork thickness)	l2	(mm)	1848	1848
4.21	Overall width	b1/b2	(mm)	1090	1090
4.22	Fork dimensions (thickness, width, length)	s / e / l	(mm)	35x100x1150	35x100x1150
4.23	Fork carriage to DIN 15 173 A/B/no			2A	2A
4.24	Fork carriage width	b3	(mm)	920	920
4.31	Ground clearance under mast, with load	m1	(mm)	95	95
4.32	Ground clearance at center of wheelbase, with load (forks lowered)	m2	(mm)	85	85
4.33	Working aisle width with 1000 x1200 mm pallets, crosswise	Ast	(mm)	3173	3173
4.34	Working aisle width with 800 x1200 mm pallets, crosswise	Ast	(mm)	2993	2993
4.35	Turning circle radius	Wa	(mm)	1475	1475
4.36	Minimum distance between centers of rotation	b13	(mm)	0	0
Performance					
5.1	Travel speed, with/without load		km/h	16 / 16	16 / 16
5.2	Lifting speed, with/without load		m/s	0.5 / 0.6	0.5 / 0.6
5.3	Lowering speed, with/without load		m/s	0.52 / 0.5	0.52 / 0.5
5.5	Rated drawbar pull, with/without load		N	2810 / 3130	2720 / 3090
5.6	Maximum drawbar pull, with/without load (5 min short duty)		N	11390 / 11710	11290 / 11660
5.7	Gradeability, with/without load		%	11 / 18	10 / 16
5.8	Maximum gradeability, with/without load		%	28 / 35	26 / 35
5.9	Acceleration time (10 metres) with/without load		s	4.1 / 3.6	4.2 / 3.7
5.10	Service brakes (mechanical/hydraulic/electric/pneumatic)			Mech/hydr.	Mech/hydr.
Electric motors					
6.1	Drive motor capacity (60 min. short duty)		kW	4.5x2	4.5x2
6.2	Lift motor output at 15% duty factor		kW	11.5	11.5
6.3	Battery to DIN 43 531/35/36 A/B/C/no			DIN 43531 A	DIN 43531 A
6.4	Battery voltage/capacity at 5-hour discharge		V/Ah	48V / 500Ah	48V / 500Ah
6.5	Battery weight		kg	715	715
6.6	Energy consumption according to VDI 60 cycle		kWh/h	-	-
Miscellaneous					
8.1	Type of drive control			AC transistor	AC transistor
8.2	Maximum operating pressure for attachments		bar	181	181
8.3	Oil flow for attachments		l/min	-	-
8.4	Noise level, value at operator's ear (EN 12053)		dB(A)	66	66
8.5	Towing coupling design / DIN type, ref.			15170 / H	15170 / H

Continuing improvement may lead to changes in these specifications.

	Mitsubishi	Mitsubishi	Mitsubishi	Mitsubishi	Mitsubishi
	FB16CPNT	FB16PNT	FB18CPNT	FB18PNT	FB20PNT
	Electric	Electric	Electric	Electric	Electric
	Seated	Seated	Seated	Seated	Seated
	1,600	1600	1800	1800	2000
	500	500	500	500	500
	373	373	373	373	384
	1395	1505	1395	1505	1505
	3034	3134	3134	3227	3459
	4053/581	4068/666	4378/556	4383/644	4759/700
	1451/1583	1540/1594	1452/1683	1539/1688	1584/1875
	SE / SE	SE / SE	SE / SE	SE / SE	SE / SE
	18x7-8	18x7-8	18x7-8	18x7-8	200/50-10
	140/55-9	140/55-9	140/55-9	140/55-9	140/55-9
	2x/2	2x/2	2x/2	2x/2	2x/2
	920	920	920	920	938
	174	174	174	174	174
	5/7.5	5/7.5	5/7.5	5/7.5	5/7.5
	2125	2125	2125	2125	2125
	80	80	80	80	80
	3290	3290	3290	3290	3290
	4342	4342	4342	4342	4342
	2050	2050	2050	2050	2050
	974	974	974	974	974
	575	575	575	575	575
	3108	3218	3108	3218	3229
	1958	2068	1958	2068	2079
	1090	1090	1090	1090	1140
	35x100x1150	35x100x1150	35x100x1150	35x100x1150	35x100x1150
	2A	2A	2A	2A	2A
	920	920	920	920	920
	95	95	95	95	95
	85	85	85	85	85
	3283	3393	3283	3393	3403
	3103	3213	3103	3213	3222
	1585	1695	1585	1695	1695
	0	0	0	0	0
	16 / 16	16 / 16	16 / 16	16 / 16	16 / 16
	0.5 / 0.6	0.5 / 0.6	0.44 / 0.6	0.44 / 0.6	0.4 / 0.6
	0.52 / 0.5	0.52 / 0.5	0.52 / 0.5	0.52 / 0.5	0.52 / 0.5
	2680 / 3070	2650 / 3050	2610 / 3050	2580 / 3020	2480 / 2970
	12020 / 12410	12160 / 12550	11950 / 12390	12090 / 12530	11980 / 12470
	11 / 16	9 / 15	9 / 15	9 / 15	8 / 14
	27 / 35	26 / 35	25 / 35	25 / 35	23 / 35
	4.3 / 3.7	4.3 / 3.8	4.3 / 3.8	4.4 / 3.8	4.5 / 3.9
	Mech./hydr.	Mech./hydr.	Mech./hydr.	Mech./hydr.	Mech./hydr.
	4.5x2	4.5x2	4.5x2	4.5x2	4.5x2
	11.5	11.5	11.5	11.5	11.5
	DIN 43531 A	DIN 43531 A	DIN 43531 A	DIN 43531 A	DIN 43531 A
	48V / 625Ah	48V / 750Ah	48V / 625Ah	48V / 750Ah	48V / 750Ah
	855	1025	855	855	1025
	-	-	-	-	-
	AC transistor	AC transistor	Impulse /AC	AC transistor	AC transistor
	181	181	181	181	181
	-	-	-	-	-
	66	66	66	66	66
	15170/H	15170/H	15170 / H	15170 / H	15170 / H

Electric Counterbalance

4 Wheel Pneumatic Tyres • 48 Volt AC Power • 1.6 – 2.0 tonnes

Characteristics					
1.1	Manufacturer (abbreviation)			Mitsubishi	Mitsubishi
1.2	Manufacturer's model designation			FB16CPN	FB16PN
1.3	Power source: (battery, diesel, LP gas, petrol)			Electric	Electric
1.4	Operator type: pedestrian, (operator)-standing, -seated			Seated	Seated
1.5	Load capacity	Q	kg	1600	1600
1.6	Load center distance	c	(mm)	500	500
1.8	Load distance, axle to fork face	x	(mm)	373	373
1.9	Wheelbase	y	(mm)	1446	1556
Weight					
2.1	Truck weight, without load / including battery (simplex mast, lowest lift height)		kg	3044	3095
2.2	Axle loading with maximum load, front/rear (simplex mast, lowest lift height)		kg	3999/645	4039/656
2.3	Axle loading without load, front/rear (simplex mast, lowest lift height)		kg	1433/1611	1541/1554
Wheels, Drive Train					
3.1	Tyres: V=solid, L=pneumatic, SE=solid pneumatic - front/rear			SE / SE	SE / SE
3.2	Tyre dimensions, front			18x7-8	18x7-8
3.3	Tyre dimensions, rear			16x6-8	16x6-8
3.5	Number of wheels, front/rear (x=driven)			2x/2	2x/2
3.6	Track width (center of tyres), front	b10	(mm)	920	920
3.7	Track width (center of tyres), rear	b11	(mm)	898	898
Dimensions					
4.1	Mast tilt, forwards/backwards	α/β	°	5/7.5	5/7.5
4.2	Height with mast lowered (see tables)	h1	(mm)	2125	2125
4.3	Free lift (see tables)	h2	(mm)	80	80
4.4	Lift height (see tables)	h3	(mm)	3290	3290
4.5	Overall height with mast raised	h4	(mm)	4342	4342
4.7	Height to top of overhead guard	h6	(mm)	2050	2050
4.8	Seat height	h7	(mm)	974	974
4.12	Tow coupling height	h10	(mm)	575	575
4.19	Overall length	l1	(mm)	3302	3412
4.20	Length to fork face (includes fork thickness)	l2	(mm)	2152	2262
4.21	Overall width	b1/b2	(mm)	1090	1090
4.22	Fork dimensions (thickness, width, length)	s / e / l	(mm)	35x100x1150	35x100x1150
4.23	Fork carriage to DIN 15 173 A/B/no			2A	2A
4.24	Fork carriage width	b3	(mm)	920	920
4.31	Ground clearance under mast, with load	m1	(mm)	95	95
4.32	Ground clearance at center of wheelbase, with load (forks lowered)	m2	(mm)	85	85
4.33	Working aisle width with 1000 x1200 mm pallets, crosswise	Ast	(mm)	3473	3588
4.34	Working aisle width with 800 x1200 mm pallets, crosswise	Ast	(mm)	3273	3388
4.35	Turning circle radius	Wa	(mm)	1900	2015
4.36	Minimum distance between centers of rotation	b13	(mm)	481	544
Performance					
5.1	Travel speed, with/without load		km/h	17 / 17	17 / 17
5.2	Lifting speed, with/without load		m/s	0.5 / 0.6	0.5 / 0.6
5.3	Lowering speed, with/without load		m/s	0.52 / 0.5	0.52 / 0.5
5.5	Rated drawbar pull, with/without load		N	2680 / 3070	2660 / 3060
5.6	Maximum drawbar pull, with/without load (5 min short duty)		N	12020 / 12410	12170 / 12560
5.7	Gradeability, with/without load		%	10 / 16	9 / 16
5.8	Maximum gradeability, with/without load		%	27 / 35	27 / 35
5.9	Acceleration time (10 metres) with/without load		s	4.3 / 3.7	4.3 / 3.7
5.10	Service brakes (mechanical/hydraulic/electric/pneumatic)			Mech./hydr.	Mech./hydr.
Electric motors					
6.1	Drive motor capacity (60 min. short duty)		kW	4.5x2	4.5x2
6.2	Lift motor output at 15% duty factor		kW	11.5	11.5
6.3	Battery to DIN 43 531/35/36 A/B/C/no			DIN 43531 A	DIN 43531 A
6.4	Battery voltage/capacity at 5-hour discharge		V/Ah	48V / 625Ah	48V / 750Ah
6.5	Battery weight		kg	855	1025
6.6	Energy consumption according to VDI 60 cycle		kWh/h		
Miscellaneous					
8.1	Type of drive control			AC transistor	AC transistor
8.2	Maximum operating pressure for attachments		bar	181	181
8.3	Oil flow for attachments		l/min	-	-
8.4	Noise level, value at operator's ear (EN 12053)		dB(A)	67	67
8.5	Towing coupling design / DIN type, ref.			15170 / H	15170 / H

Continuing improvement may lead to changes in these specifications.

	Mitsubishi	Mitsubishi	Mitsubishi
	FB18CPN	FB18PN	FB20PN
	Electric	Electric	Electric
	Seated	Seated	Seated
	1800	1800	2000
	500	500	500
	373	373	384
	1446	1556	1556
	3099	3161	3325
	4315/584	4343/618	4693/631
	1428/1671	1533/1628	1557/1768
	SE / SE	SE / SE	SE / SE
	18x7-8	18x7-8	200/50-10
	16x6-8	16x6-8	16x6-8
	2x/2	2x/2	2x/2
	920	920	938
	898	898	898
	5/7.5	5/7.5	5/7.5
	2125	2125	2125
	80	80	80
	3290	3290	3290
	4342	4342	4342
	2050	2050	2050
	974	974	974
	575	575	575
	3302	3412	3423
	2152	2262	2273
	1090	1090	1140
	35x100x1150	35x100x1150	35x100x1150
	2A	2A	2A
	920	920	920
	95	95	95
	85	85	85
	3473	3588	3599
	3273	3388	3399
	1900	2015	2015
	481	544	544
	17 / 17	17 / 17	17 / 17
	0.44 / 0.6	0.44 / 0.6	0.4 / 0.6
	0.52 / 0.5	0.52 / 0.5	0.52 / 0.5
	2610 / 3060	2600 / 3040	2510 / 3000
	11950 / 12400	12110/12550	1202 /12510
	9 / 16	9/15	8 / 14
	25 / 35	25/35	23 / 35
	4.3 / 3.7	4.4 / 3.8	4.4 / 3.8
	Mech./hydr.	Mech./hydr.	Mech./hydr.
	4.5x2	4.5x2	4.5x2
	11.5	11.5	11.5
	DIN 43531 A	DIN 43531 A	DIN 43531 A
	48V / 625Ah	48V / 750Ah	48V / 750Ah
	855	1025	1025
	AC transistor	AC transistor	AC transistor
	181	181	181
	-	-	-
	67	67	67
	15170 / H	15170 / H	15170 / H

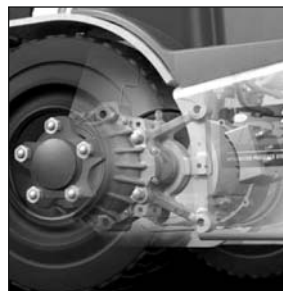

Wet disc brakes



Easy on/off access



Lateral battery exchange



Large floor space



Multi-function display

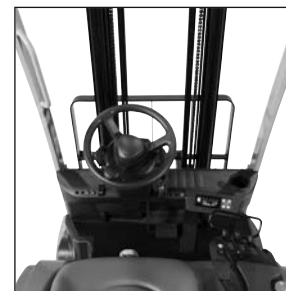

Ergonomic control layout

EDIA EM

THE ELECTRIC DIAMOND

EDIA stands for environmentally friendly electric energy and for the quality and enduring value of a diamond.

EDIA brilliantly combines the latest electronic technology with ErgoCentric design to create a whole new level of confidence and intuitive driveability.

Electric Counterbalance

3 Wheel Pneumatic Tyres • 48 Volt AC Power • **1.3 – 2.0 tonnes**

Mast Performance and Capacity

Mast Type	FB13PNT - FB20PNT				FB13PNT	FB15PNT	FB16CPNT	FB18CPNT	FB16PNT	FB18PNT	FB20PNT
	h3 mm	h1 mm	h4 mm	h2 / h5 mm	Q @ c=500 mm kg	Q @ c=500 mm kg	Q @ c=500 mm kg	Q @ c=500 mm kg	Q @ c=500 mm kg	Q @ c=500 mm kg	Q @ c=500 mm kg
Simplex	2000	1480*	3045	80	1300	1500	1600	1800	1600	1800	2000
	2560	1760*	3605	80	1300	1500	1600	1800	1600	1800	2000
	2760	1860*	3805	80	1300	1500	1600	1800	1600	1800	2000
	3000	1980*	4045	80	1300	1500	1600	1800	1600	1800	2000
	3290	2125	4335	80	1300	1500	1600	1800	1600	1800	2000
	3530	2245	4575	80	1300	1500	1600	1800	1600	1800	2000
	3720	2385	4765	80	1300	1500	1600	1800	1600	1800	2000
	4090	2570	5135	80	1300	1500	1600	1750	1600	1800	2000
	4480	2775	5525	80	1275	1475	1600	1700	1600	1800	2000
	5000	3035	6045	80	1200	1400	1525	1625	1600	1750	1925
	5500	3285	6545	80	1125	1325	1425	1550	1500	1675	1850
6000	3535	7045	80	1050	1250	1300	1425	1400	1550	1650	
Duplex	2800	1880*	3845	835	1300	1500	1600	1800	1600	1800	2000
	3000	1980*	4045	935	1300	1500	1600	1800	1600	1800	2000
	3295	2125	4340	1080	1300	1500	1600	1800	1600	1800	2000
	3515	2245	4560	1200	1300	1500	1600	1800	1600	1800	2000
	3700	2385	4745	1340	1300	1500	1600	1800	1600	1800	2000
	4030	2570	5075	1525	1300	1500	1600	1750	1600	1800	2000
Triplex	3710	1780*	4755	735	1300	1500	1600	1800	1600	1800	2000
	4010	1880*	5055	835	1300	1500	1600	1750	1600	1800	2000
	4310	1980*	5355	935	1275	1475	1600	1725	1600	1800	2000
	4750	2125	5795	1080	1225	1425	1550	1650	1600	1800	2000
	5090	2245	6135	1200	1175	1375	1500	1600	1600	1775	1900
	5490	2385	6535	1340	1125	1325	1450	1550	1550	1675	1825
	5990	2570	7035	1525	1075	1275	1375	1375	1450	1500	1650
	6490	2830	7535	1785	950	1050	1050	1050	1175	1175	1350
7000	3035	8045	1990	725	725	725	725	850	850	1100	

(Consult your distributor for the maximum back tilt allowed to obtain the capacities specified)

* lower than overhead guard

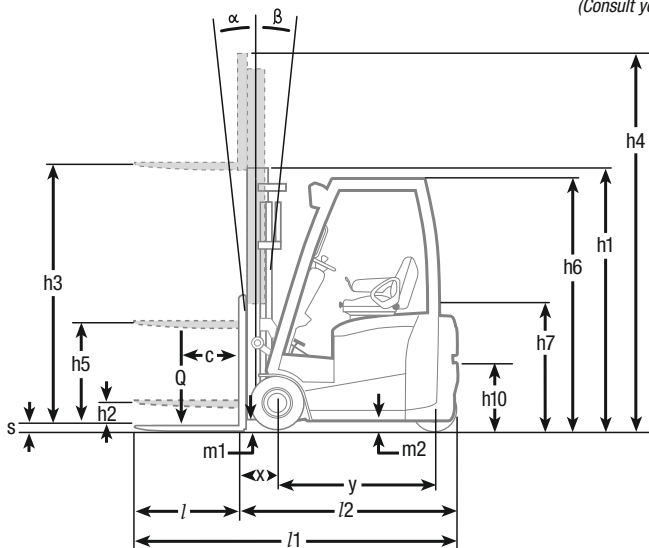

- h1 Height with mast lowered
- h2 Standard free lift
- h3 Lift height
- h4 Height with mast raised
- h5 Full free lift
- Q Lifting capacity, rated load
- c Load centre (distance)

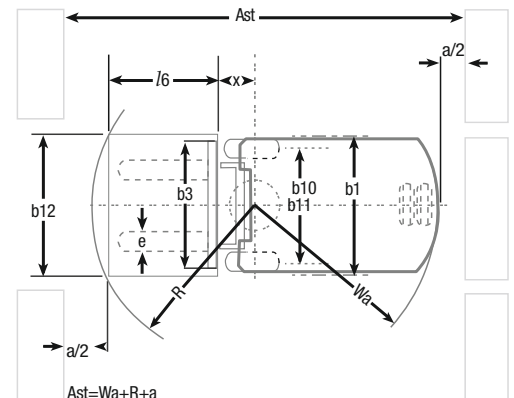

- $A_{st} = W_a + R + a$
- A_{st} = Working aisle width with load
- a = Safety clearance (200 mm)
- l_6 = Pallet length (800 or 1000 mm)
- b₁₂ = Pallet width (1200 mm)

Integrated Presence System 2 (IPS2)



Hydraulic and travel interlock systems prevent all movement if the driver is not seated. Automatic warnings remind the driver to fasten the seatbelt and apply the parking brake. An electronic parking brake automatically activates when the driver leaves the seat.

Electric Counterbalance

4 Wheel Pneumatic Tyres • 48 Volt AC Power • **1.6 – 2.0 tonnes**

Mast Performance and Capacity

Mast Type	FB16CPN • FB20PN				FB16CPN	FB18CPN	FB16PN	FB18PN	FB20PN
	h3 mm	h1 mm	h4 mm	h2 / h5 mm	Q @ c=500 mm kg	Q @ c=500 mm kg	Q @ c=500 mm kg	Q @ c=500 mm kg	Q @ c=500 mm kg
Simplex	2000	1480*	3040	80	1600	1800	1600	1800	2000
	2560	1760*	3605	80	1600	1800	1600	1800	2000
	2760	1860*	3805	80	1600	1800	1600	1800	2000
	3000	1980*	4045	80	1600	1800	1600	1800	2000
	3290	2125	4335	80	1600	1800	1600	1800	2000
	3530	2245	4575	80	1600	1800	1600	1800	2000
	3720	2385	4765	80	1600	1800	1600	1800	2000
	4090	2570	5135	80	1600	1800	1600	1800	2000
	4480	2775	5525	80	1600	1775	1600	1800	2000
	5000	3035	6045	80	1600	1700	1600	1775	1925
	5500	3285	6545	80	1550	1625	1600	1725	1850
6000	3535	7045	80	1200	1200	1325	1325	1750	
Duplex	2800	1880*	3845	835	1600	1800	1600	1800	2000
	3000	1980*	4045	935	1600	1800	1600	1800	2000
	3295	2125	4340	1080	1600	1800	1600	1800	2000
	3515	2245	4560	1200	1600	1800	1600	1800	2000
	3700	2385	4745	1340	1600	1800	1600	1800	2000
	4030	2570	5075	1525	1600	1800	1600	1800	2000
Triplex	3710	1780*	4755	735	1600	1800	1600	1800	2000
	4010	1880*	5055	835	1600	1800	1600	1800	2000
	4310	1980*	5355	935	1600	1775	1600	1800	2000
	4750	2125	5795	1080	1600	1725	1600	1800	1950
	5090	2245	6135	1200	1600	1675	1600	1750	1900
	5490	2385	6535	1340	1550	1625	1600	1700	1850
	5990	2570	7035	1525	1275	1275	1400	1400	1775
	6490	2830	7535	1785	900	900	1025	1025	1325
7000	3035	8045	1990	625	625	750	750	1000	

(Consult your distributor for the maximum back tilt allowed to obtain the capacities specified)

* lower than overhead guard

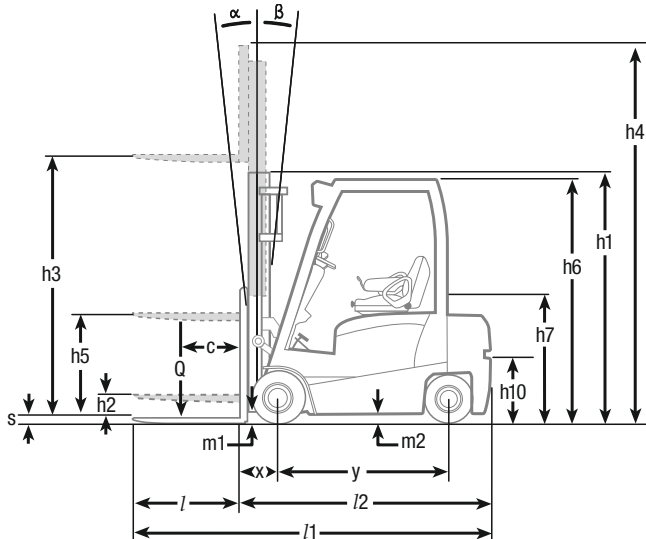

- h1 Height with mast lowered
- h2 Standard free lift
- h3 Lift height
- h4 Height with mast raised
- h5 Full free lift
- Q Lifting capacity, rated load
- c Load centre (distance)

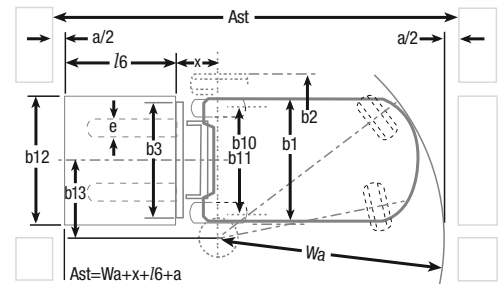

- Ast = Working aisle width with load
- a = Safety clearance (200 mm)
- l6 = Pallet length (800 or 1000 mm)
- b12 = Pallet width (1200 mm)

Controlled Cornering System (CCS)



Sensors measure the angle of turn and a safe speed limit is computed. Drive motor speed is continually adjusted as the angle changes. Normal speed quickly resumes as the course straightens.

IPX4



Indicates waterproofing of the truck's components to a specification sufficient for operation in a range of wet conditions, including wind-blown rain and water splashed from any direction.



Effortless fingertip controls



Rapid service access

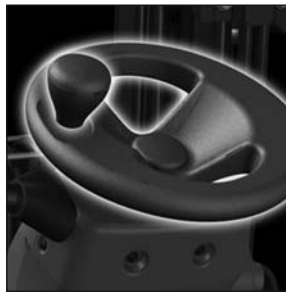

FeatherTouch electric steering

Frame and body

- **Low centre of gravity** ensures the best residual capacities in the market.

Mast and fork assembly

- **Exceptional visibility** through a wide range of high-strength, clear-view masts allows handling with total confidence.

Drive

- **Efficient drive (and lift) motors** combine with strong regenerative braking and advanced electric steering technology to minimise energy consumption and extend shifts.

Steering system

- **FeatherTouch electric steering** lowers energy consumption, minimises noise, allows precise, effortless control and requires almost no maintenance.

Brakes

- **Wet disc brakes** are perfect for wet, salty or dusty workplaces, delivering virtually maintenance-free performance and producing no particulate pollution.
- **Electronically activated parking brake** is applied automatically whenever the operator leaves the seat and can be activated manually by simply pressing a button.

- **Hill hold** automatically prevents accidental rolling, even on steep ramps.
- **Controlled Cornering System (CCS)** sets appropriate limits for any turning angle.

Hydraulics

- **Reliable lift (and drive) motors** have been proven to withstand intensive work in the most demanding of applications without breakdown.

Electrical and control systems

- **Simple performance settings** include five pre-set modes for instant programming by the driver.
- **Full programmability** and diagnostics via laptop connection allows precise adjustment of many parameters by service engineer to meet the exact needs of each operator and application.
- **Integrated Presence System 2 (IPS2)** pioneered by Mitsubishi prevents all movement of the truck and its mast if the operator is not seated.
- **Versatile battery compartment** accommodates DIN size batteries with a variety of capacities, for maximum compatibility with user's equipment and needs.

- **Rapid lateral battery exchange option** for multi-shift or heavy duty applications allows simple, quick, safe removal and replacement.

- **Bright white halogen lights** or optional LED lights – front and rear – deliver 'see-and-be-seen' safety.

Other features

- **IPX4 waterproofing** includes IP54 specification as standard for drive and hydraulic motors, allowing operation even in splashing water and wind-blown rain.
- **RapidAccess** features for easy servicing include quick-release floor plate and wide-opening battery cover.

Options include

- Load weight indicator
- Side shifters
- Fingertip hydraulic controls
- Cabin packages
- Rear grab handle with horn
- Wide-view mirror



for much more information on EDIA EM visit the microsite:

www.edia-mitsubishi.com

when reliability is everything...

Like any product bearing the Mitsubishi name, our materials handling equipment benefits from the huge resources and cutting-edge technology of one of the world's largest corporations. So when we promise you **quality, reliability and value for money**, you know it's a guarantee we have the power to deliver.

Every model in our comprehensive, award-winning range of forklift trucks and warehouse equipment is built to a high specification and is designed to keep on working for you... day after day... year after year... whatever the job... whatever the conditions.

To ensure your truck stays in constant productive action, we have a network of local dealers – hand-picked for their commitment to customer care... and backed up by the Mitsubishi Forklift Trucks organisation. No matter where you are, we have a dealer close by – ready and willing to meet your needs.

That friendly local service covers everything from identifying the perfect model and configuration for your application to providing competitive, flexible finance and maintenance packages, unbeatable warranties, long and short term hire, and highly responsive field service and repairs... as well as the industry's quickest and most reliable parts supply.

Only Mitsubishi can give you this combination of global engineering excellence and outstanding local support... only Mitsubishi offers you such a quality product at such an affordable price... and only Mitsubishi places reliability as high as you do in its priorities. Contact your local dealer now and see what Mitsubishi can do for you.

You can find your nearest dealer at www.mitforklift.com



CESM1375 (10/11)

© 2011 MCFE

Printed in The Netherlands

mitforklift@mcf.nl www.mitforklift.com

NOTE: Performance specifications may vary depending on standard manufacturing tolerances, vehicle condition, types of tyres, floor or surface conditions, applications or operating environment. Trucks may be shown with non-standard options. Specific performance requirements and locally available configurations should be discussed with your distributor of Mitsubishi forklift trucks. Mitsubishi follows a policy of continual product improvement. For this reason, some materials, options and specifications could change without notice.